



Volume 115

2022

p-ISSN: 0209-3324

e-ISSN: 2450-1549

DOI: <https://doi.org/10.20858/sjsutst.2022.115.5>



Journal homepage: <http://sjsutst.polsl.pl>

Article citation information:

Manafov, E., Isgandarov, I., Huseynov, F. Investigating the protection system of electric motors based on its main working parameters. *Scientific Journal of Silesian University of Technology. Series Transport*. 2022, **115**, 63-74. ISSN: 0209-3324.

DOI: <https://doi.org/10.20858/sjsutst.2022.115.5>.

Elshan MANAFOV¹, Islam ISGANDAROV², Farid HUSEYNOV³

INVESTIGATING THE PROTECTION SYSTEM OF ELECTRIC MOTORS BASED ON ITS MAIN WORKING PARAMETERS

Summary. This research was devoted to the creation of a protection system for electric motors used in industry and transport, based on modern and traditional sensors. In the course of operation, the malfunctions of electric motors have been investigated and it was found that the accident modes occur mainly due to exceeding the permissible values of the current, voltage and temperature parameters. Modern sensors of current, voltage, and temperature have been compared and the most effective ones were selected for use in electric motors. Based on reasoning from these sensors, a protection system for a low-power electric motor has been developed in the laboratory. In addition, in the Multisim application software package, a simulation of the operation of the protection system at different voltage and current values was performed, and a circuit of the sensor control unit and the power source for powering the protection system was constructed. It has been proposed to apply such a multi-parametric complex protection system for electric motors, especially in transport.

Keywords: electric motor, short circuit, overload, current sensors, voltage sensors, temperature sensors, relay control, protection system

¹ Faculty of Physics and Technology, National Aviation Academy, Prospekt of Mardakan 30, Baku AZ1045, Azerbaijan. Email: elshan_manafov@mail.ru. ORCID: <https://orcid.org/0000-0001-5697-577X>

² Faculty of Physics and Technology, National Aviation Academy, Prospekt of Mardakan 30, Baku AZ1045, Azerbaijan. Email: islam.nus@mail.ru. ORCID: <https://orcid.org/0000-0002-5292-7954>

³ Faculty of Physics and Technology, National Aviation Academy, Prospekt of Mardakan 30, Baku AZ1045, Azerbaijan. Email: huseynovferid17525257@gmail.com. ORCID: <https://orcid.org/0000-0002-5325-0279>

1. INTRODUCTION

In industry, transport and various fields of technique, AC (asynchronous, synchronous) and DC current machines are used. Currently, it is used more than asynchronous machines that function in motor mode.

Regarding the development of static converters, the capabilities of induction motors have significantly increased. Thus, the possibilities of using these motors in electric transport are considered more effective. In modern electric vehicles, the short-circuit rotor asynchronous motor is mainly used as an electric motor.

As in all electrical machines, there is always a high probability of occurrence of abnormal and failure regimes and damages caused to induction motors. Therefore, the working process and operating parameters of induction motors, especially in railway transport, operating in difficult working conditions should be constantly monitored.

One of the most important issues in increasing the efficiency and durability of the power supply system of vehicles is to provide reliable and accurate control of its electrical parameters and optimal protection against voltage, current and other parameters in case of accident operation.

From this research, it has been identified that the application of modern electronic sensors to control the technical condition of electric motors can provide a more reliable mode of operation.

It is known that the increase in load for one reason or the other during the use of electrical equipment results in the failure of the device, and at best, damage to the elements of the electrical circuit of the device. Faults of electrical origin occur as a result of the effects of short-circuit currents, electric arcs and sparks, reduced insulation resistance as well as other causes. This shortcoming requires more cost and workers. In recent years, significant research has been conducted to develop new methods required to monitor the technical condition of electric motors, overcoming the shortcomings of traditional methods. The incidence of motor failures or abnormal modes increases with the complexity of its operating mode; therefore, it is essential to develop more sensitive and modern protection systems based on the results of additional failures and the results obtained.

Furthermore, only the temperature parameter is used to conduct diagnostic monitoring of traction electric motors - produced by some leading companies in the world - operating in railway transport. The results of this research show that the temperature parameter alone does not provide complete and perfect information covering the technical condition of the motors and several parameters are required to be added to these parameters in a row to obtain more accurate results. Hence, complex diagnostic monitoring of electric motor and the creation of multi-parameter protection systems based on it is actual [1-5].

2. STATEMENT OF THE PROBLEM AND SELECTION OF SENSORS FOR A MULTI-PARAMETER PROTECTION SYSTEM

The technical condition of electrical equipment is carried out primarily by checking the level of reliability and parameters. It is possible to create more reliable and sensitive protection systems from the information obtained from the diagnostic monitoring of the technical condition.

To ensure more stable working conditions, the reserve and reliability indicators in the motors need to be considered. Suppose two identical motors are used as a backup in a system. If one of them fails, the other motor will run at full system load.

Suppose two identical motors are used as a backup in a system. If one of them fails, the other motor will run at full system load. The breakdown intensities of the motors are the same and constant, $\lambda = \lambda_1 = \lambda_2 = 0,0005$ 1/s. In this case, it is demanded to identify the exponential law of the probability of proper operation of the motor at $t = 400$ hours.

Since the motors are of the same type, the probability of a malfunction is as follows:

$$P(t) = 2e^{-\lambda_1 \cdot t} - e^{-2 \cdot \lambda_2 \cdot t} = 2 \cdot e^{-0,0005 \cdot 400} - e^{-0,0005 \cdot 400} = 0,9671 \quad (1)$$

According to the data, the average operating time of the system is calculated as follows:

$$T_O = \frac{1}{\lambda} \left(1 + \frac{1}{2} \right) = \frac{3}{2} \cdot \frac{1}{0,0005} = 3000 \text{ hour} \quad (2)$$

To increase the probability of proper operation of the electric motor, it is necessary to ensure its protection against jumps and possible accidents during the transition process.

Acute voltage fluctuations, current overloads, short circuits, temperature changes, etc. in such cases, the establishment and application of a multi-parameter protection system to prevent equipment, source and load failures are of particular importance.

During the operation of electric motors, non-standard and possible accident cases can be divided into the groups stated below:

- Abnormal and accident modes occurring in the network (voltage above or below the nominal value, frequency change, etc.)
- Non-standard currents and accidents (inter-phase short-circuits in three-phase motors, breakage in stator or rotor windings, leakage of insulation due to temperature rise caused by overload or short-circuit currents, etc.)

Special protection devices are developed and applied to protect motors from damage in unacceptable and accident modes. As it is known, a short-term decrease in voltage leads to a decrease in the torque of electric motors used in transport. After the voltage is restored, the motor restores its torque and returns to the nominal operating mode. In this case, the value of the current required by the motor increases sharply, which, in turn, can lead to the activation of the protection. The setting parameters of the protection installed in the electric motor should be selected so that the protection does not start and turn on the motor circuit when the short-term voltage drops. For this, special attention should be given to the selectivity of the security system.

In addition to the current and voltage parameters, one of the other main parameters subject to protection is the operating temperature of the windings. It is unacceptable to increase the temperature in the windings. If the operating temperature of the motor windings exceeds the $+10^\circ\text{C}$ heat limit for any period of time, the insulation of the stator and rotor windings is reduced by half the service life.

It is known that there are plenty of sensors based on various physical effects that control the values of current and voltage: resistive, inductive and capacitive sensors based on Ohm's law; transformer sensors based on Faraday's electromagnetic induction law; voltage and current sensors based on the Hall's effect, and traditional voltage and current sensors based on other effects [1, 6, 7].

At the same time, there are modern sensors based on the application of Rogovsky winding, electro-optical and magnetic-optical effects intended for non-contact measurement of high voltages and currents.

Resistors, transformers and Hall-effect sensors are mainly used to measure the electrical parameters of modern locomotives used in railway transport.

Resistive sensors are simple and economical, the principle of operation is based on the direct proportion of the voltage across the reference resistor connected in series with the load in the current circuit (Ohm's law), which can be used to measure direct and alternating currents.

The external appearance and connection diagram of different types of widely used current sensors are shown in Figure 1, and the constructive and principle diagram of the voltage sensors are shown in Figure 2.

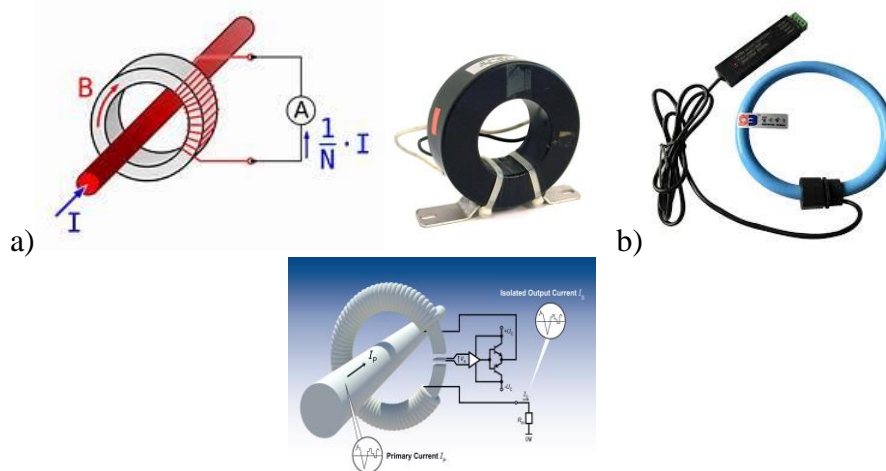

Fig. 1. Constructive and principle scheme of current sensors:
a) Current transformer; b) Rogowski winding

In the laboratory, a current transformer was used to control the current value in the protection system designed for a low-power asynchronous motor. In high-power motors, the introduction of the Rogowsky windings is considered to be more promising than the current sensors [8].

Voltage sensors based on electrical, electromagnetic, electromechanical, electro-thermal, electro-optical and other similar physical effects are widely used in theoretical and practical research.

The measurement procedure, which is the selection of the appropriate type of sensors, is determined by the type and level of voltage. It is important to amplify the signals to record low voltages in the measurement circuit and reduce the received signals to an acceptable level at high voltages [9-11].

Voltage dividers (resistive, capacitive and inductive), voltage transformers, electronic voltage sensors, etc. are generally used as voltage sensors (Figure 2).

The use of voltage transformers for measuring high voltages is considered more expedient.

A resistive divider was used to control the voltage value in the protection system designed for the low-power electric motor. The resistive divider is considered simpler and technically more economical.

Voltage transformers are often used as voltage sensors in high-power motors. Due to the large dimensions of voltage transformers, it is more expedient to use a resistive shunt and a resistive divider as voltage sensors, where possible [12, 13].

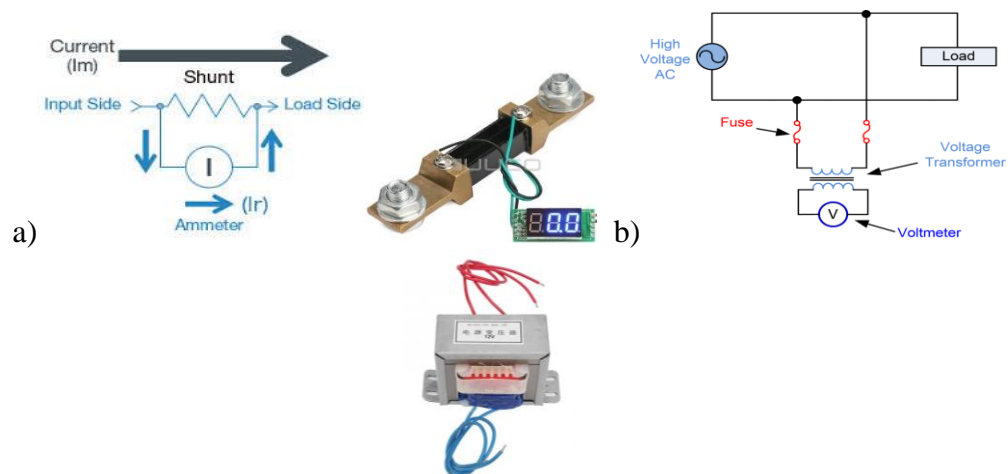

Fig. 2. Constructive and principle scheme of voltage sensors:
a) resistive shunt; b) voltage transformer

Several methods are used to measure temperature. These include fiber-optic temperature sensors, electrical resistance thermometers, thermographic methods, thermocouple-based temperature sensors, etc. (Figure 3).

As a contact temperature sensor for determining the temperature value in high-powered motors, the thermocouple is considered the most suitable.

The main advantage of a thermocouple-based module sensor is the transmission of a signal with a direct relay output. Based on the signal received from the sensor, it is possible to both protect the motor and perform diagnostic analysis of the recorded data, as well as set up special alarm systems by displaying the data on special displays. Thanks to this, it is possible to ensure a more reliable and stable operation of the motor.

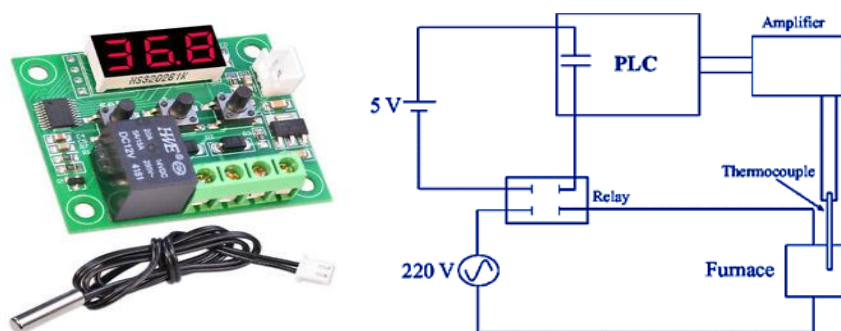

Fig. 3. Constructive and principle scheme of temperature sensor

Experiments were carried out on the electric motor according to the three important parameters mentioned above, and a protection system based on automatic control with relay output was installed. The operation of the relay is determined by the electrical signal received from the sensors. Based on the electrical signals, in any abnormal and accident situation, the relay motor controlled by the protection system is disconnected from the mains. MLE00137 of type relay was used to protect the motor (Figure 4).

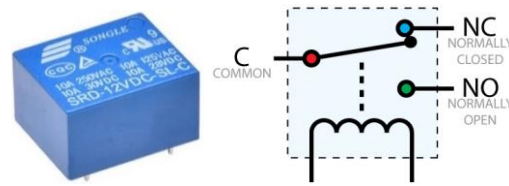

Fig. 4. MLE00137 type protection relay

This type of relay is distinguished by its compactness, large process switching capabilities, start-up speed, etc. This relay is able to provide normal operation when the supply voltage of the working winding is in the range of 6-15 V.

3. MAGNETIC FIELD MEASUREMENT AND OUTPUT SIGNAL ANALYSIS

In laboratory conditions, an experimental stand built upon a low powerful motor was developed to simulate malfunctions that may occur in motors and control the changes occurring in electrical parameters.

One of the most modern and promising methods intended for diagnosing motor malfunctions and building a protection-warning system based on this is the measurement and spectral analysis of the magnetic field.

The results of the analysis show that the defects and malfunctions in the electric motor have a significant effect on the spectrum of the electromagnetic field generated outside it. By continuously monitoring the magnetic aura of the motor in working conditions, it is possible to determine the change of some parameters and create special protection and warning systems based on the results obtained. For example, overload, increase and decrease of voltage, change of current frequency, etc.

In research, the use of a Hall sensor as a sensor to allow non-contact diagnostics without interfering with motor design is preferred. Thus, this sensor can be considered one of the most informative sensors allowing accessing the condition of the motor by monitoring the electromagnetic spectrum.

In experimental research, the use of the KY-024 Hall sensor, which is less sensitive to external influences, was preferred. The connection scheme and design structure of these types of sensor is given in Figure 5.

The recorded oscillograms of the magnetic field change in different modes of the electric motor studied using the KY-024 sensor are given in Figure 6.

As seen from the analysis of the oscillograms, in normal, failures or defects, overload and other conditions, the magnetic field around the electric motor changes with a big difference. Thus, based on the recorded data, it is possible to create a modern protection-warning system by diagnosing the motor while at the same time analyzing the signals at the output of the sensor.

4. MODELING OF THE MULTI-PARAMETER PROTECTION SYSTEM

In reality, the development and implementation of a working version of the system that can perform the above functions is accompanied by many technical problems. Therefore, since modern applications are more accessible for individual and complex simulation of functions, it is more advantageous to develop an imitation model of the system through these programs.

This, in turn, allows the creation of a working model based on an imitation model of the system in research and production facilities, which allows one to design a real prototype of the system. In our research, based on the Multisim program, an imitation model of the device was developed, protecting against short circuits, overloads, as well as drops in voltage and overvoltage in the phase of the motor powered by an electric power source.

Relay control is applied at both high and low voltage limits at specified values. In the Multisim program, the protection circuits are built and modeled according to the voltage limit. Schematics of protection activation at normal, high and low voltage values are shown in Figures 7, 8 and 9. The green LED turning on indicates that the voltage is within the normal range. While, in abnormal modes, the red LED turning on indicates that the mains voltage has exceeded the allowable limit.

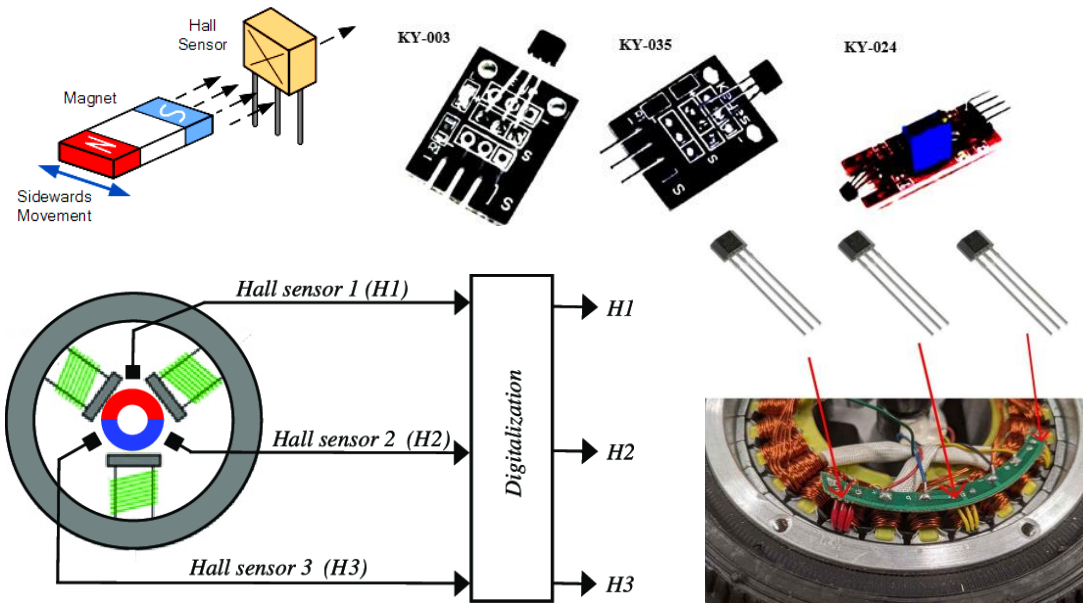

Fig. 5. Traditional connection scheme and constructive descriptions of the Hall sensor

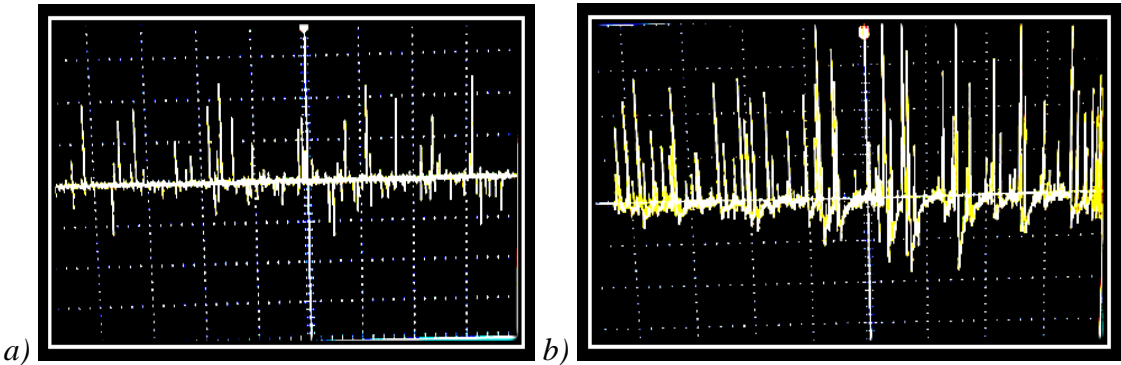

Fig. 6. Oscillograms of the motor magnetic field: a) in normal operation; b) in overload

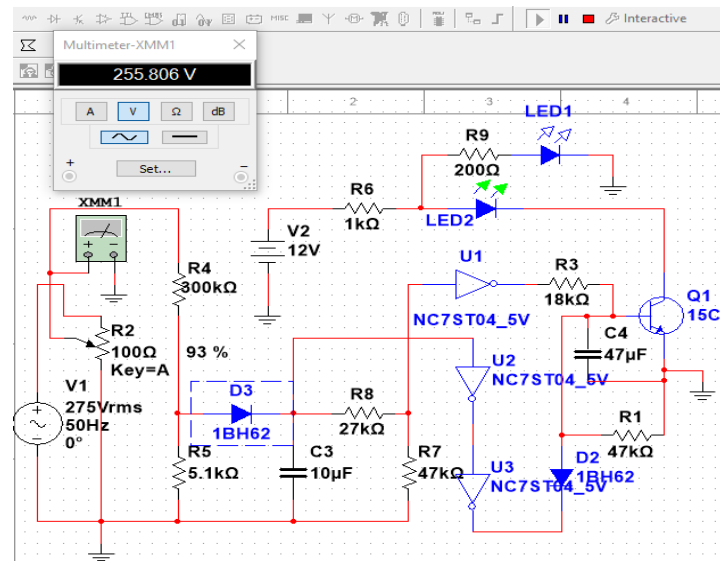

Fig. 7. Electrical circuit of the protection device at the range of normal operating voltages (168-260 V)

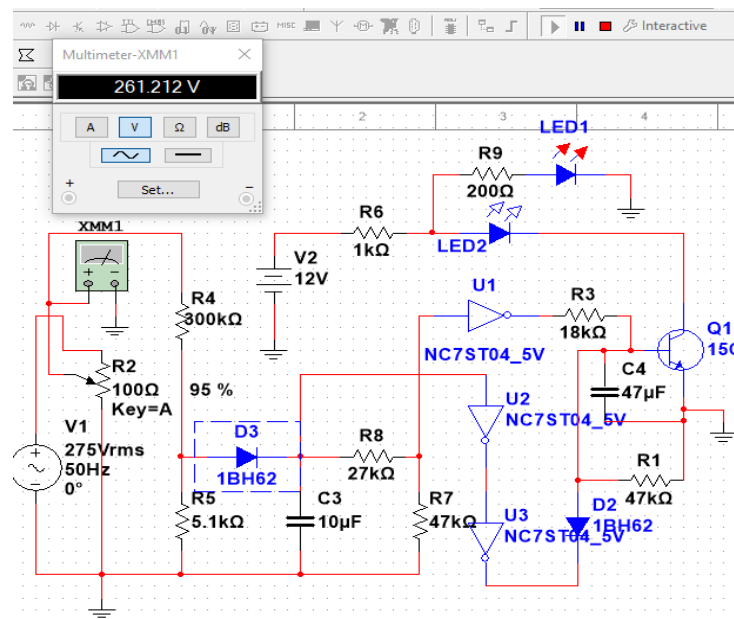

Fig. 8. Electrical circuit of the protection device at the value of the voltage above the nominal ($U_{in} > 260$ V)

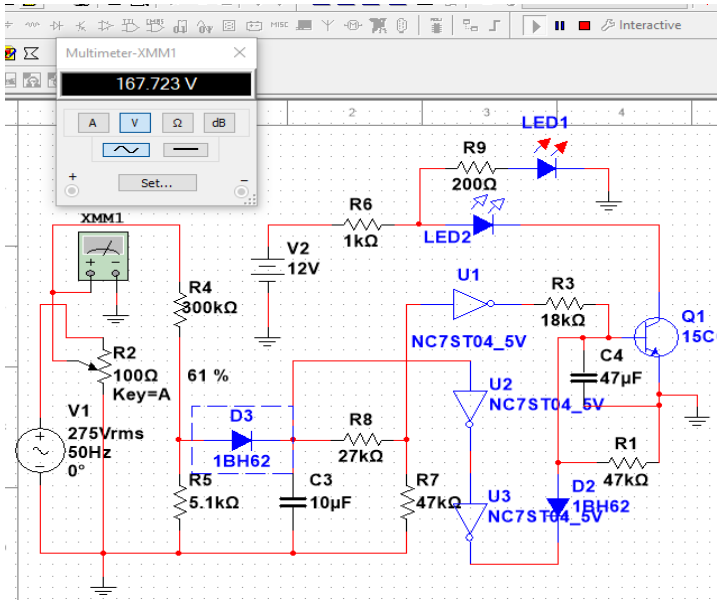

Fig. 9. Electrical circuit of the protection device at a voltage below the nominal value ($U_{in} < 168 \text{ V}$)

The current protection ensures the opening of the motor from the food source by activating the relay at the limits of the current above the specified values. A resistive shunt-based protection circuit was used to simulate current protection in Multisim, and the current variation in the intended range was simulated by applying an adjustable voltage to the input of the circuit. The simulation results for the current performed in Multisim are given in Figures 10 and 11.

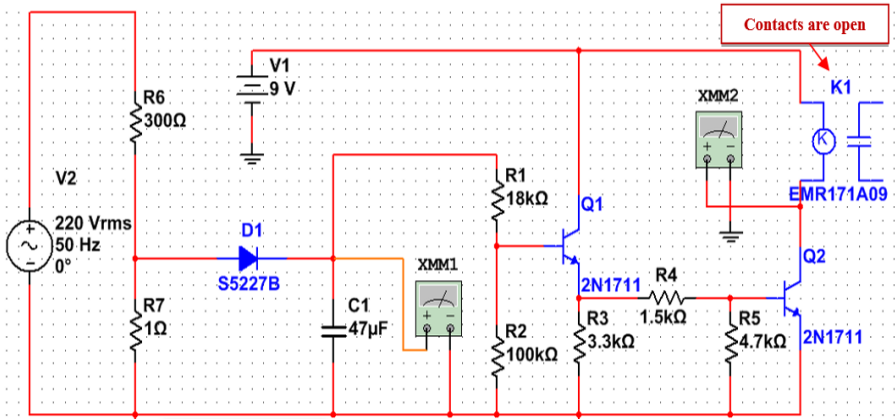

Fig. 10. Electrical circuit of the protection device at the nominal value of current

The rated motor current is 0,55 A at 220 V. In our case, the critical value of overloading, that is, the minimum value of the current required for the protection of operation, is 0,9 A.

Built on the logic elements of the protection system, a second transformless unit was developed to provide the nominal 5 and 9 V supply voltages required to power the electronic control unit for voltage limits, transistor control unit for current limits, temperature protection unit and output relay unit. An autotransformer was used to obtain a controlled voltage value in laboratory conditions.

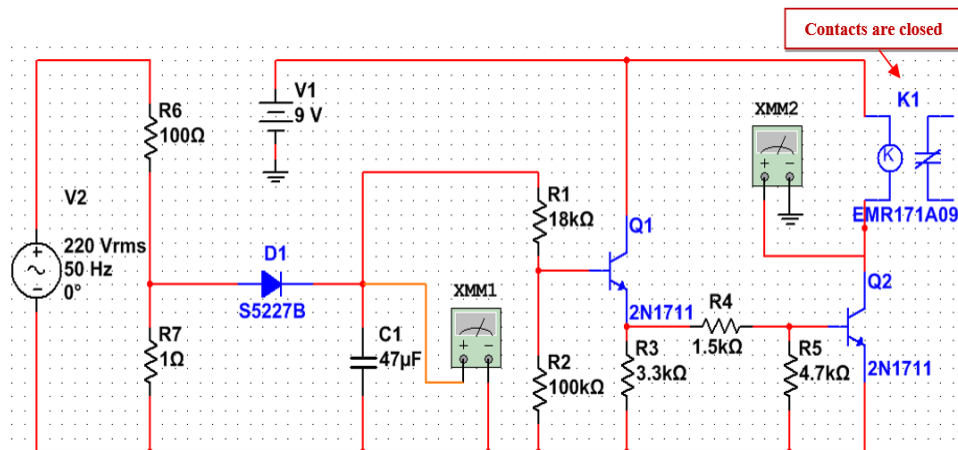

Fig. 11. Electrical circuit of the protection device during accident operation (short circuit or allowable value overload)

As mentioned, the second power supply of the unit is for the power supply of sensors of the voltage, current and temperature also of the control and protection system. Based on the transformerless power supply circuit for the power supply of the protection system, the input voltage is 170 – 275 V, the output voltage is 5,1 V, the relay circuit is 7,5 – 12 V, and the total current required by the parametric stabilized power supply is 40-65 mA. Since there is no autotransformer in the *Multisim* software base, the regulated voltage is supplied to the circuit via a potentiometer.

For sufficient load capacity of the power supply, it is possible to use a transistor in the output circuit of the stabilizer as an amplifier. Since the base-emitter junction of the transistor has a voltage drop of 0,7 – 0,8 V, a stabilitron with a stabilization voltage of 5,6 – 5,7 V should be selected to provide 5 V at the output. For the selected stabilitron to operate in stabilization mode, its current in the range $I_{st} = 3 - 50$ mA, as well as the current of the base circuit and stabilitron together can be selected 10 - 15 mA, given that the rated voltage of the transistor is higher than 50 and the current at the output of the transistor is less than 100 – 200 mA.

The type of relay designed to replace the power chains of the selected relays and powerful analog motors can normally operate at wide voltages (in this case, 7 – 15 V), thus, stabilization is not required for the relay power circuit. If necessary, the same stabilization scheme can be applied.

A protection system based on the relay control was installed and experiments were performed on the motor to control the temperature parameter. The normal temperature of the motor windings is identified using the insulation class. Traction electric motors operated in most modern locomotives used in railway transport are equipped with C-class insulation (200°C and above).

$$T_{open} \geq 38,5^{\circ}C$$

$$T_{norm} \leq 38,4^{\circ}C \quad (3)$$

$$T_{rec.t} = 35,7^{\circ}C$$

- T_{open} – operating temperature of the protection system;
- T_{norm} – normal motor operating temperature;
- $T_{rec.t}$ – reconnection temperature;

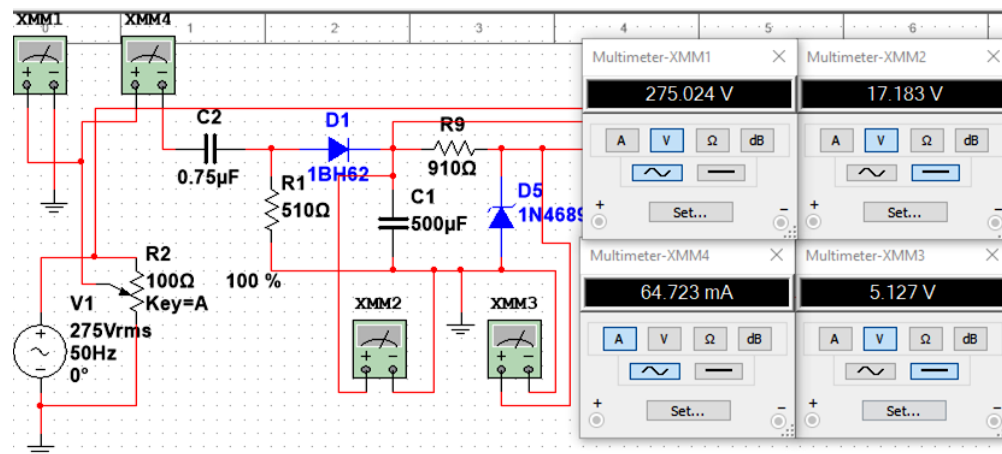

Fig. 12. Electrical circuit of the second power supply of the protection device

To connect the protection system (opening the motor) in the motor, which is the object of study, the temperature of the windings should reach T_{open} . These temperature values were conditionally taken for the experiments. To restore the operation mode of the motor started through protection, the temperature of the windings must be conditionally lowered to the reconnection temperature value $T_{rec.t}$. When the winding temperature cools down to normal operating temperature (that is, reconnection temperature), the relay restarts the motor.

A modular thermocouple was used to determine the temperature of the motor windings. The input of the module is supplied with a constant supply voltage of 9V. The output terminals are similarly connected to the motor and relay. The thermocouple transmits the signal to the module, where it compares the opening temperature with the normal temperature and sends a pulse to the relay. The relay turns on the motor following the received impulse or restarts the motor with protection.

5. CONCLUSION

Thus, in this research, the faults of the electric motor were investigated and it was determined that the accident modes occur mainly due to exceeding the permissible values of current, voltage and temperature parameters. Further, modern current, voltage, and temperature sensors were compared and those with the best performance for use in electric motors were selected. According to the mentioned main parameters, the main control and power supply blocks of the protection system were analyzed in the Multisim application program and a model of the system providing complex protection in the laboratory was practically established.

Based on theoretical and practical research, it can be assumed that it is possible to show the warning signals on the appropriate display by protecting the temperature, voltage and current of electric motors used in transportation and industry and transmitting also the results sent to the relay control circuit and the central control station.

Having applied the modern sensors we offer, it is possible to ensure a stable operating mode of electric motors assisted by a complete multi-parameter protection system.

References

1. Ferreira Fernando J.T.E., André M. Silva, Aníbal T. de Almeida. 2018. "Single-Phasing Protection of Line-Operated Motors of Different Efficiency Classes". *IEEE Transactions on Industry* 54(3).
2. Karpavičius Paulius, Vytautas Ostaševičius, Vytautas Jūrėnas, Jolantas Baskutienė. 2017. „Self-powered wireless sensor system application for cutting process control”. *Mechanika* 23(3): 456-461.
3. Kozłowski E., K. Antosz, D. Mazurkiewicz, J. Sęp, T. Żabiński. 2021. „Integrating advanced measurement and signal processing for reliability decision-making”. *Eksploatacja i Niezawodność – Maintenance and Reliability* 23(4): 777-787.
4. Mazurkiewicz D. 2014. „Computer-aided maintenance and reliability management systems for conveyor belts”. *Eksploatacja i Niezawodność – Maintenance and Reliability* 16(3): 377-382.
5. Vaičekauskis M., R. Gaidys, V. Ostaševičius. 2013. „Influence of boundary conditions on the vibration modes of the smart turning tool”. *Mechanika* 3: 296-300.
6. Dickinson R., S. Milano. 2002. "Isolated Open Loop Current Sensing Using Hall Effect Techn". In: *Optimized Magnetic Circuit*. Allegro MicroSystems, Inc.C.NH, USA. P. 1-12.
7. Jianghua Feng, Junfeng Xu, Wu Liao, Yong Liu. 2017. "Review on the Traction System Sensor Technology of a Rail Transit Train". *Sensors* 17(6): 13-26.
8. Данилов А.Б. 2004. "Современные промышленные датчики тока". *Современная электроника* 10: 26-28. [In Russian: Danilov A.B. "Modern industrial current sensors". *Modern electronics*].
9. Bayrak M. 2002. "A New Digital Relay for Generator Protection Against Asymmetrical Faults". *IEEE Trans. On Power Delivery* 17(1): 54-59.
10. Jose E.D., T.B. Roy, C. Chai, L. Yu. 1995. "Stall Protection of Large Induction Motors". *IEEE Transactions on Industry Applications* 31(5): 1159-1166.
11. Novak T., A.L. Morley, C.T. Frederick. 1988. "Sensitive Ground-Fault Relaying". *IEEE Transactions on Industry Applications* 24(5): 853-861.
12. Paoletti G.J., A. Rose. 1989. "Improving Existing Motor Protection for Medium Voltage Motors". *IEEE Transactions on Industry Applications* 25(3): 456-464.
13. Zocholl S.E. 1989. "Integrated and Protective Relay Systems". *IEEE Transactions on Industry Applications* 25(5): 889-893.

Received 07.01.2022; accepted in revised form 03.03.2022



Scientific Journal of Silesian University of Technology. Series Transport is licensed under a Creative Commons Attribution 4.0 International License