



Volume 103

2019

p-ISSN: 0209-3324

e-ISSN: 2450-1549

DOI: <https://doi.org/10.20858/sjsutst.2019.103.2>



Journal homepage: <http://sjsutst.polsl.pl>

**Article citation information:**

Homišin, J. Static optimisation of mechanical systems based on the method of extremal regulation. *Scientific Journal of Silesian University of Technology. Series Transport*. 2019, **103**, 15-29. ISSN: 0209-3324. DOI: <https://doi.org/10.20858/sjsutst.2019.103.2>.

Jaroslav HOMIŠIN<sup>1</sup>

**STATIC OPTIMISATION OF MECHANICAL SYSTEMS BASED ON THE METHOD OF EXTREMAL REGULATION**

**Summary.** A change in torsional stiffness of pneumatic tuners can be achieved by changing the pressure of the gaseous medium in the course of the mechanical systems' operation or while idle. Based on this statement, we tuned mechanical systems with torsional vibration when they are either idle or when they reach stable condition during operation. The principle of tuning mechanical systems with torsional vibration during operation when their condition is stable lies in the appropriate adaptation of basic dynamic properties (dynamic torsional stiffness and damping factor) of the pneumatic tuner to the dynamics of the system. This was achieved with a control system that helps create a closed control feedback loop. In this way, we can continuously change, that is, adapt the dynamic properties of the pneumatic tuner to the dynamics of the mechanical system so that no dangerous torsional vibrations occur while the system is in operation mode.

**Keywords:** static optimisation of mechanical systems, method of extremal regulation, continuous tuning of mechanical systems

<sup>1</sup> Faculty of Mechanical Engineering. Technical University of Košice. Letná 9 Street, 042 00 Košice, Slovakia.  
Email: [jaroslav.homisin@tuke.sk](mailto:jaroslav.homisin@tuke.sk)

## 1. INTRODUCTION

Change in the torsional stiffness of pneumatic tuners can be achieved by changing the pressure of the gaseous medium, either in the course of operation or when the mechanical systems are idle. This implies the two proposed ways of tuning mechanical systems with torsional vibration (MSTV):

- o tuning mechanical systems with torsional vibration when idle, thus ensuring the condition of tuning the said systems.
- o tuning mechanical systems with torsional vibration during operation when they are in stable condition, thus ensuring the condition of continuous tuning of the said systems.

The principle of tuning the mechanical systems during operation when their condition is stable lies in the appropriate adjustment of the pneumatic tuner's basic dynamic properties (dynamic torsional stiffness and damping coefficient) to the dynamics of the system. This is ensured with a control system that helps create a closed control feedback loop. In this way, we can continuously change, that is, adapt the dynamic properties of the pneumatic tuner to the dynamics of the mechanical system so that no dangerous torsional vibration occurs during the system operation mode.

The proposed methods of tuning mechanical systems are possible to apply due to the control circuits and control systems, for which the author has been granted patent protection<sup>2</sup>, and they can be implemented as follows:

- via a control system that ensures a continuous change in the characteristics of the pneumatic couplings.
- by means of a control system that enables a continuous tuning of the mechanical system.
- by applying a pneumatic coupling with an additional control system.
- through static optimisation based on the method of extremal regulation.
- by using a self-regulating pneumatic coupling.

## 2. BASIC PRINCIPLE AND FOUNDATION OF STATIC OPTIMISATION OF MECHANICAL SYSTEMS BASED ON THE METHOD OF EXTREMAL REGULATION

As already mentioned, dangerous torsional vibration is very common in mechanical systems driven by pistons, acting in the role of either the driving or the driven aggregates. Intense torsional vibration causes excessive dynamic stress to the entire machine. For this reason, a justified need exists to control dangerous torsional vibration in these mechanical systems and the mechanical jitter generated thereby. Currently, this problem is solved by the appropriate adaptation of dynamic properties of the flexible shaft coupling to the dynamics of

---

<sup>2</sup>CZ 259225 B6. *A regulating system to ensure a continuous change in the characteristics of a pneumatic coupling*. Technical University, Košice. (Homišín J.). 11.11.1987. SK 276927 B6. *Regulating system for affecting continuous tuning of a mechanical system*. TU Košice. (Homišín J.). 07.06.1992. SK 279626 B6. *A mechanical system suitable for continuous tuning*. TU Košice. (Homišín J.). 07.06.1992. SK 278025 B6. *Flexible pneumatic shaft coupling with self-regulation capability*. TU Košice. (Homišín J.). 11.10.1995. SK 278272 B6. *Pneumatic couplings with additional constant twist angle control*. TU Košice. (Homišín J.). 03.07.1996. SK 278499 B6. *Control circuit of mechanical systems with torsional vibration*. TU Košice. (Homišín J.). 09.07.1997. PL 216901 B1. *Continuously tuned mechanical system*. TU Košice. (Homišín J.). 22.05.2014 SK 288202 B6. *Ensuring continuous tuning of mechanical systems by applying a control system*. TU Košice. (Homišín J.). 12.06.2014.

the system. This means that the mechanical system must be suitably dynamically tuned in advance to the main harmonic component of the piston machine.

The aim is to achieve the right resonance from the main harmonic component, that is, the critical speed exists at a sufficient distance from the working speed range of the machine in question.

However, the present tuning method will only be suitable if there are no unforeseen (accidental) failure effects during the system's operating mode. That is, if there is no mechanical failure, especially of the piston machine.

In the event of failure of the piston machine [1], [2], [3], [4], [5], [6] highly intense resonance of components with minor – lower harmonic excitation occurs in the operating mode, resulting in critical speed.

It can be deduced from the dynamic point of view that it is possible to characterise the MSTV as systems most often operating in the supercritical region with relatively fast transition upon their start up and shut down. In terms of control, however, they belong to a group of controlled systems with incomplete information. Incompleteness of information is manifested mainly in the area of unforeseen failure effects, that is, in the area of accidental failures.

Drawing on the MSTV characteristics, as well as on the advantages and disadvantages of the current solution to the given problem in the area of dangerous torsional vibration [7], [8], we proposed to control the torsional vibration and the mechanical vibration generated thereby through static optimisation (direct optimisation) based on the method of extremal regulation during stable operating condition.

Our main criterion for optimising any MSTV is to achieve minimum torsional vibration values and minimal mechanical vibration generated consequently.

In this respect, it should be noted that the static optimisation of MSTV by the method of extremal regulation is currently, not being practically implemented at all. This is mainly due to the fact that basic conditions have not yet been established for the possible implementation of this method. However, the existence of a pneumatic torsional vibration tuner, that is, an element that is able to change its basic characteristics during operation, in particular, its dynamic torsional stiffness, provides all the prerequisites for enabling extremal regulation in MSTV.

Implementing static optimisation in MSTV requires the following conditions be met:

- ❖ MSTV must meet the basic requirements for continuous tuning, that is, tuning the system while it is running in a stable condition.
- ❖ It is not necessary to know the mathematical model controlling the MSTV to carry out their static optimisation. Nevertheless, it is necessary to know whether the purpose function of the system (function of input and output variables) has an extreme [9], [10], [11], [12], [13], [14], [15], [16].

## **2.1. Characteristics and execution of continuous tuning of mechanical systems with torsional vibration**

Drawing on the nature of the patents<sup>3</sup>, it is clear that the system at hand must include a pneumatic torsional tuner<sup>4</sup> regulated by the control system<sup>5</sup> of Fig.1.

---

<sup>3</sup>SK 279626 B6. *A mechanical system suitable for continuous tuning*. TU Košice. (Homišín J.). 07.06.1992. PL 216901 B1. *Continuously tuned mechanical system*. TU Košice. (Homišín J.). 22.05. 2014 SK 288202 B6. *Ensuring continuous tuning of mechanical systems by applying a control system*. TU Košice. (Homišín J.). 12.06.2014.

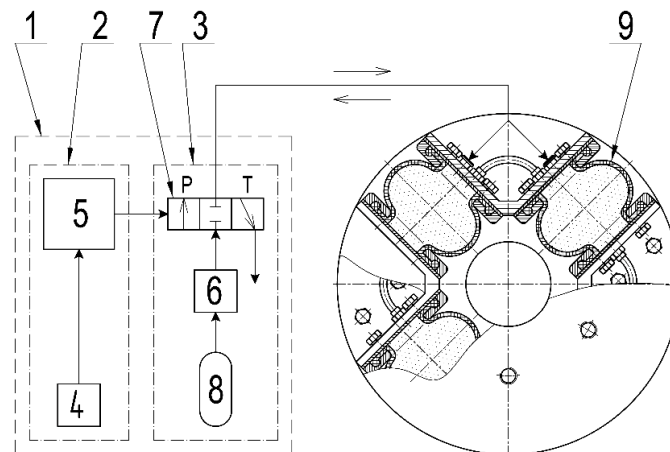

Fig. 1. Schematic representation of the regulation of continuous change in the characteristics of the pneumatic tuner by means of a control system.

Fig.1 is a schematic representation of the control system and a schematic representation of how the pneumatic torsional tuner is controlled.

The control system (1) consists of a controlling (2) and an actuating subsystem (3). The controlling subsystem (2) features a microprocessor (5) and a piezoelectric sensor of mechanical vibration acceleration (4). The sensor (4), located on the mechanical system, sends an electrical signal to the microprocessor (5), proportional to the system's mechanical vibration. The actuating subsystem (3) consists of an electromagnetic switchboard (7), which is connected to the gaseous medium reservoir (8) via a control valve (6). By switching the two-position electromagnetic switchboard (7), the microprocessor (5), which constitutes the basic control component of the entire control system (1), causes it to move, thereby increasing or decreasing the pressure of the gaseous medium in the compressive space of the pneumatic torsional vibration tuner through the supply circuit *P* or discharge circuit *T*.

When the mechanical system operates in an unfavourable operating mode, the whole system starts jittering due to the magnitude of torsional vibration, the acceleration of which is measured by a mechanical vibration sensor (4). After the microprocessor (5) receives and evaluates the electrical signal proportional to the system's mechanical jitter, the switchboard (7) is switched to the supply position *P* or a discharge position *T*. As a result, the pressure of the gaseous medium in the pneumatic elastic elements (9) of the pneumatic tuner's compression space changes, which represents a continuous change in its basic dynamic properties, that is, dynamic torsional stiffness, while the mechanical system is running.

The result of the operation of the control system is that, due to a continuous change in the pressure of the gaseous medium in the pneumatic tuner, a change in its basic dynamic property, that is, dynamic torsional stiffness is achieved. By changing the dynamic torsional stiffness, the intrinsic frequency of the system changes, thus, adapting to the frequency of the *i*-th harmonic component of the load torque so that the system does not operate in resonance with any torque excitation component, that is, until the following condition is met:

$$\Omega_0 \neq i \cdot \omega. \quad (1)$$

<sup>4</sup>SK 6101 Y1. *Flexible pneumatic shaft coupling*. TU Košice. (Homišin J.). 03.04.2012.

<sup>5</sup>CZ 259225 B6. *A regulating system to ensure a continuous change in the characteristics of a pneumatic coupling*. Technical University, Košice. (Homišin J.). 11.11.1987. SK 276927 B6. *Regulating system for affecting continuous tuning of a mechanical system*. TU Košice. (Homišin J.). 07.06.1992.

## 2.2 The trend of the special purpose function of the implemented mechanical system with torsional vibration

As part of the basic requirements set out, in the static optimisation of MSTV implemented through the application of extremal regulation, it is necessary to know in advance whether the trend of the system's special purpose function will have an absolute or a relative minimum in the set operating mode. With respect to the above requirement, the trend of the special purpose function at the implemented MSTV was to be identified and verified. The trends of the special purpose function were established theoretically, that is, by calculation, based on the theoretical model and practically, on the basis of experimental measurements performed.

### 2.2.1 Special purpose function's trends established by calculation

The calculated trends of the MSTV special purpose function are shown in Fig. 2a, b, c. They represent the resonance curve of the twist angle  $\varphi_d$  of the pneumatic tuner dependent on the pressure of the gaseous medium  $p_s$  inside of it. The twist angle  $\varphi_d$ , expressed by relation (2), characterises the output, that is, the controlled quantity, and the pressure of the gaseous medium  $p_s$ , the input, that is  $p_s$  say, the action causing variable.

$$\varphi_d = \sum_{i=1}^n \Phi_i \cdot \sin[(i\omega t + \gamma_i) + \beta_i]. \quad (2)$$

The amplitude value of the harmonic component of the twist angle, expressed by (3), mostly depends on the frequency ratio of the  $i$ -th harmonic component of the load torque and the intrinsic frequency of the system ( $i\omega/\Omega_0$ ).

$$\Phi_i = \frac{M_i}{I_1 \cdot \Omega_0^2} \cdot \frac{1}{\sqrt{\left[1 - \left(\frac{i\omega}{\Omega_0}\right)^2\right]^2 + \left(\frac{i\omega}{\Omega_0}\right)^2 \cdot \left(\frac{2\chi}{\Omega_0}\right)^2}}. \quad (3)$$

The intrinsic frequency  $\Omega_0 = \sqrt{k_{ed}/I_{red}}$  is influenced by the dynamic torsional stiffness, which according to (4), is a function of the pressure of the gaseous medium  $p_s$  in the pneumatic tuner.

$$k_{ed} = 441,664 + 9,333 \cdot p_s. \quad (4)$$

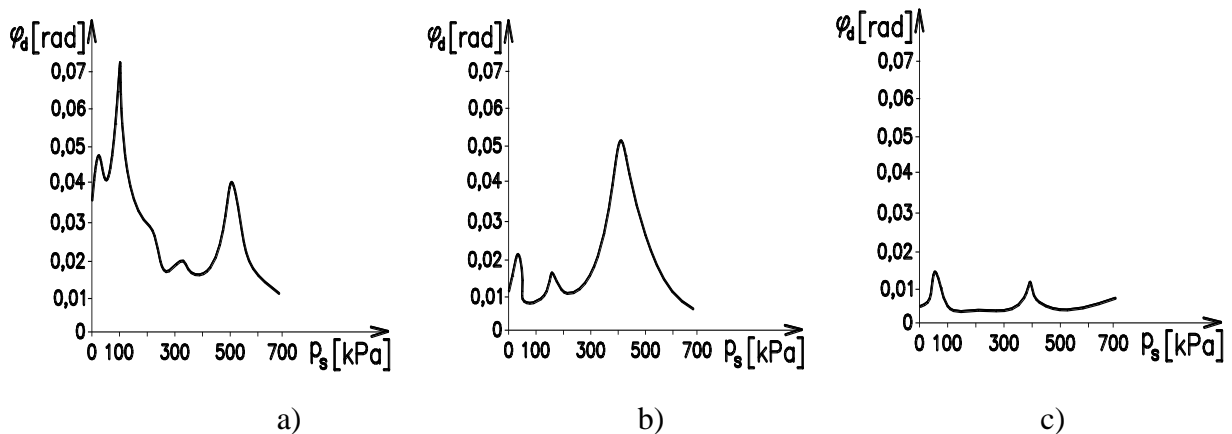

Fig. 2. The trends of the special purpose functions of the dynamic twist angle  $\varphi_d$  dependent on the pressure of  $p_s$  gaseous medium  $p_s$  in the pneumatic torsional tuner.

The trends of the special purpose function were construed at constant excitation speed  $n = 400 \text{ min}^{-1}$  (Fig. 2a),  $n = 760 \text{ min}^{-1}$  (Fig. 2b) and  $n = 1100 \text{ min}^{-1}$  (Fig. 2c) with a simulated fault variable characterised by uneven excitation of the individual compressor cylinders. In the present case, it was understood that the first and third cylinders operate at 15% greater power and the second cylinder at 15% less than the average power per cylinder.

Based on the above-mentioned trends of the special purpose function of the modelled MSTV, it can be stated that they have clear relative minimums.

### 2.2.2 Trends of the special purpose function of the system established experimentally

Practical measurements were made on the mechanical system implemented as per Fig. 3. The trends of the dynamic load torque component were measured by a torque sensor (8) and simultaneously, the jitter generated in the mechanical system was measured by a piezoelectric sensor (12).

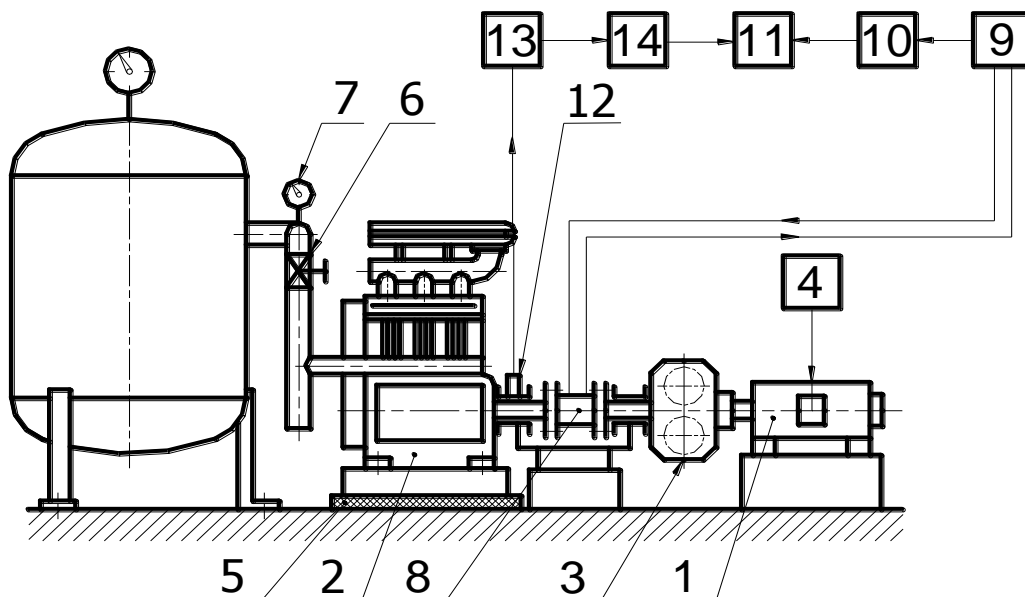

Fig. 3. Implemented mechanical system with schematic interconnection of the measuring apparatus applied.

The measurements were made assuming balanced excitation of the individual compressor cylinders at a constant speed of  $n = 760 \text{ min}^{-1}$ . The pressure of the gaseous medium in the pneumatic tuner was changed during the measurements to the extent of  $p_s = 0 \div 700 \text{ kPa}$  with a change after  $100 \text{ kPa}$ .

After amplification by the amplifier (9) and filtering by the band frequency filter (10), the electrical signal from the torque sensor (8) was recorded by a measuring tape recorder (11). Similarly, the electrical signal from the piezoelectric sensor (12), located on the torque sensor bearing housing, was simultaneously recorded by the tape recorder (11) after amplification by the amplifier (13) and the band frequency filter (14).

The recorded signals were further processed by a narrowband spectral analyzer, with the output in the form of the frequency spectrum characteristic trends of the  $A_M$  dynamic load torque component (Fig. 4) and the jitter amplitudes of the  $A_{CH}$  system (Fig. 5).

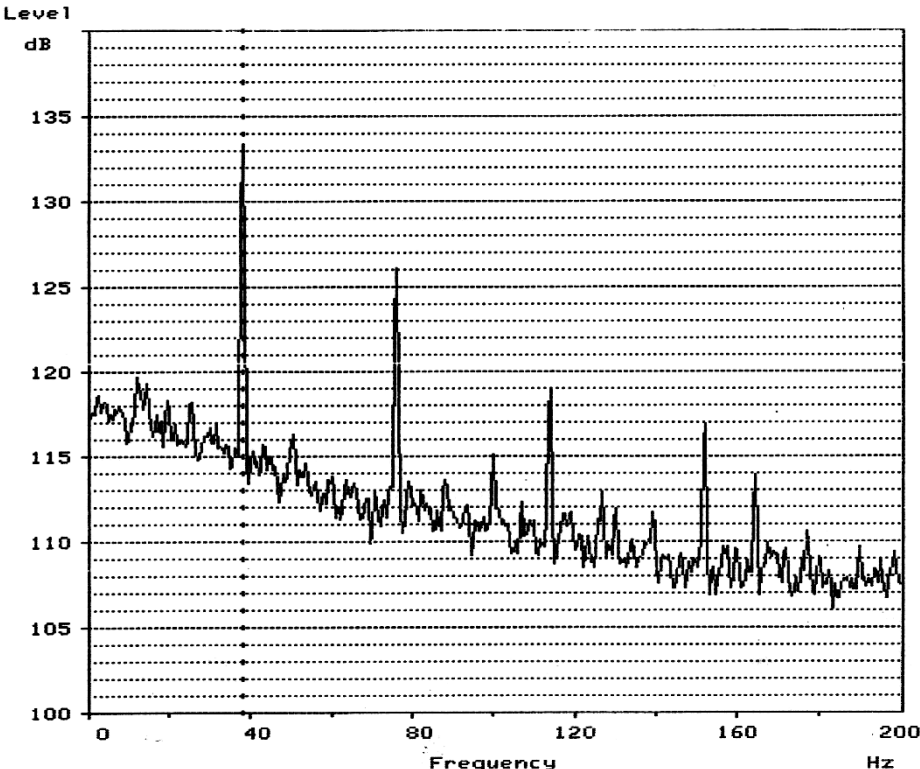

Fig. 4. Frequency spectrum characteristic of torque load  $A_M$  when applying a pneumatic tuner with gaseous medium pressure  $p_s = 400 \text{ kPa}$ .

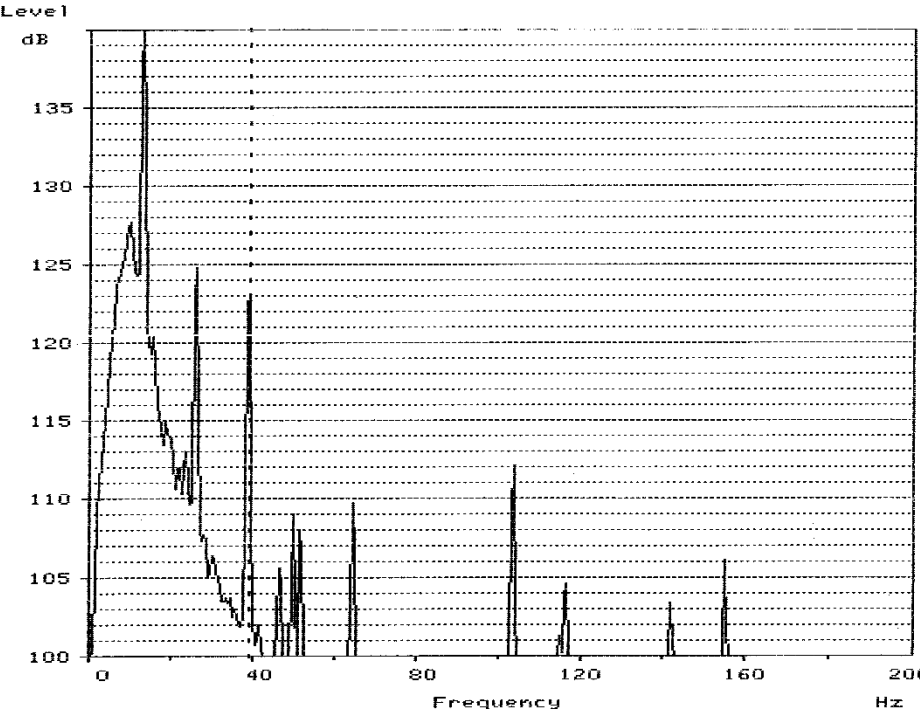

Fig. 5. Frequency spectrum characteristics of the  $A_{CH}$  amplitude jitter when applying the pneumatic tuner with the gaseous medium pressure of  $p_s = 400 \text{ kPa}$ .

From the results of the practical measurements, it is clear that the most significant amplitudes were at the first, second and third harmonic components of the speed frequency. Since the amplitudes of the first and second harmonic components were influenced by the imbalance of the rotating parts and the misalignment of the shafts of the given system, the evaluation will show the results of the frequency spectrum characteristics of the torque amplitude  $A_M$  (Fig. 4) and the mechanical jitter of the  $A_{CH}$  system (Fig. 5) shall relate to the amplitude of the third harmonic component. The reason behind this is the fact that the third harmonic component of the rotational frequency manifests itself mainly by the action of the torsional vibration generated in the mechanical system (by the action of the excitation device, in our case the compressor).

Amplitude curves of the load torque's dynamic component  $A_M$  were processed from the frequency spectrum characteristics obtained (Fig. 6) and from the  $A_{CH}$  jitter amplitude (Fig. 7) dependent on the pressure of the gaseous medium in the pneumatic tuner.

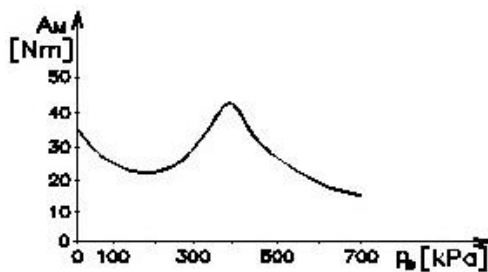

Fig. 6. The amplitude curve of the torque load dynamic component  $A_M$  dependent on the pressure of the gaseous medium  $p_s$  in the pneumatic tuner

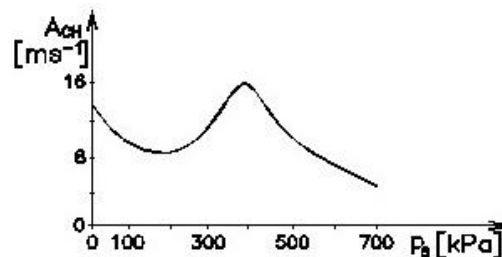

Fig. 7. The jitter amplitude curve of the implemented mechanical system  $A_{CH}$  dependent on the pressure of the gaseous medium  $p_s$  in pneumatic tuner

The trend of Fig. 6 or Fig. 7 is understood to be the trend of the output variable  $A_M$  or  $A_{CH}$ , dependent on the input variable  $p_s$ , hence, as a special purpose function of the implemented MSTV. The figure shows that the dependence of  $A_M = f(p_s)$  and  $A_{CH} = f(p_s)$  has its minimum extreme in the range of the gaseous medium pressures between  $p_s = 200 \text{ kPa}$  and  $700 \text{ kPa}$ .

### 2.2.2. Control circuit and control algorithm to ensure static optimisation of mechanical systems with torsional vibration

Static optimisation of MSTV can be achieved by the method of extremal regulation by step change in the action variable according to the control circuit as shown in Fig. 8<sup>6</sup>.

The control circuit (Fig. 8) consists of a controlled MSTV (1), a piezoelectric sensor of mechanical jitter (2), which sends an electrical signal to an extremal controller (4), proportional to the mechanical jitter of the  $A_{CH}$ . Through built-in control algorithm (Fig. 9), the extremal regulator processes the electrical signal and with the aim to search for the minimum extreme, it controls the actuator (5), characterised in Fig. 1, through a two-position electromagnetic switchboard (7). By controlling the actuator, we regulate the action variable  $p_s$ , that is, by supplying the gaseous medium or by discharging it, we increase or reduce the pressure in the pneumatic tuner.

<sup>6</sup>CZ 259225 B6. A regulating system to ensure a continuous change in the characteristics of a pneumatic coupling. Technical University, Košice. (Homišin J.). 11.11.1987.



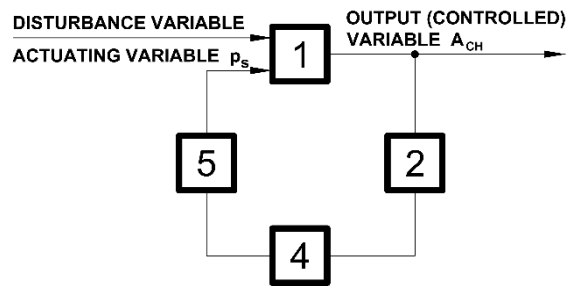

Fig. 8. A control circuit to ensure extremal control in a mechanical system with torsional vibration.

It is obvious from the control algorithm (Fig. 9) that after determining the time between two consecutive measurements  $\Delta t$  and after determining the bandwidth of the controlled variable  $\nu$  deadband, either the first value of torsional vibration  $A_T(t_{i-1})$  or of mechanical jitter  $A_{CH}(t_{i-1})$  is measured. After measuring another  $A_T(t_i)$  or  $A_{CH}(t_i)$  value, the static optimisation of the MSTV, controlled by the extremal regulation, will comply with the said algorithm.

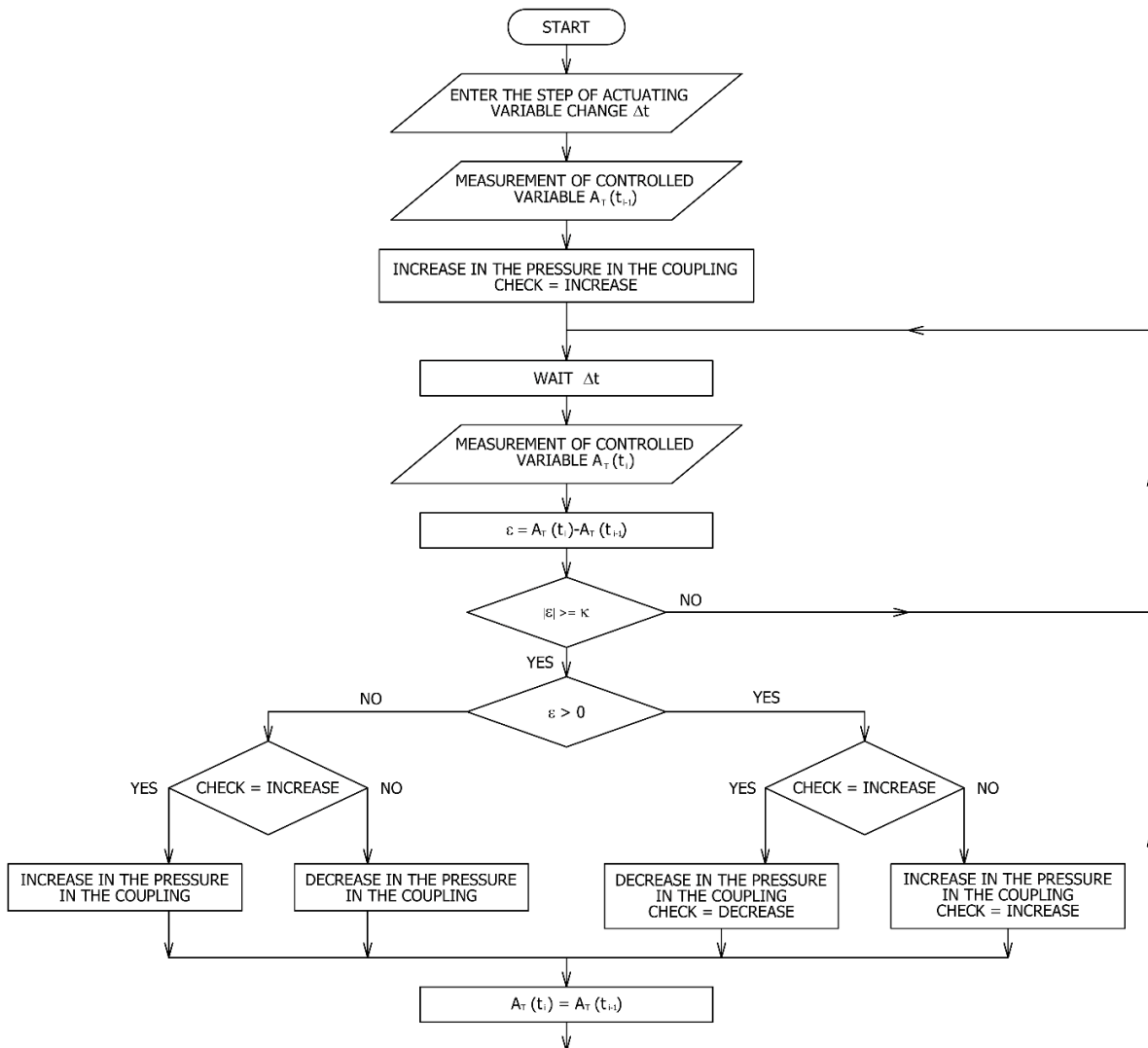

Fig. 9. Algorithm controlling the extremal regulation.

### 3. RESULTS OF THE APPLICATION OF EXTREMAL REGULATION TO THE IMPLEMENTED MECHANICAL SYSTEM WITH TORSIONAL VIBRATION

Fig. 10 shows the dynamic tuning of the implemented mechanical system by pneumatic torsional vibration tuner, via the amplitude curves of the dynamic components of the twist angle of the pneumatic tuner dependent on the speed (*a*, *b*, *c*). At the same time, the figure also shows the influence of the secondary harmonic components on the magnitude of the torsional vibration of the mechanical system, which is presented as dynamic characteristics trends *b*, *c*.

Trend *a* shows the dynamic characteristic in case of a trouble-free operation of the piston machine. The failure rate of the piston machine is shown as characteristics of the trend *b*, *c*. The trend *b* characterises the failure of uneven excitation of the individual cylinders of the piston machine (in the range  $\pm$  of 15%), while the trend *c* is characterised by the failure of one cylinder that ceased to operate. The individual trends are processed in the above figure with the pressure of the gaseous medium in the pneumatic tuner being  $p_s = 700 \text{ kPa}$ .

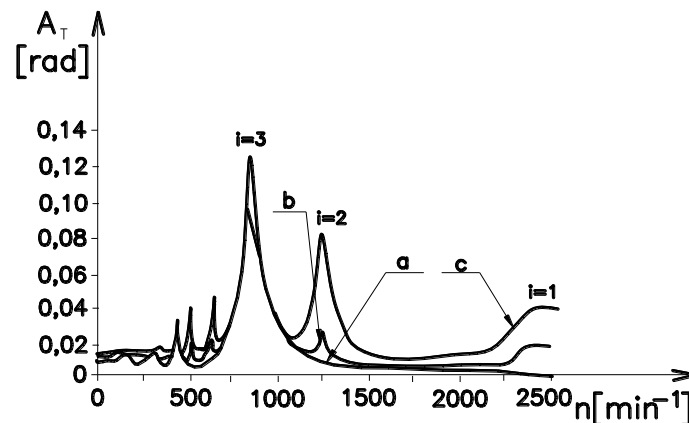

Fig. 10. Amplitude curves of dynamic components of the twist angle  $\varphi_d$  of the pneumatic tuner dependent on the speed  $n$ .

Fig.10 shows that the condition of removing the critical speed to a sufficient distance from the operating speed range is met by the trends of all characteristics. This means that MSTV has been suitably dynamically tuned in advance to the main harmonic component ( $i = 3$ ) of the torque load.

Within the operating speed range ( $n = 1000 \div 2500 \text{ min}^{-1}$ ), the dynamic characteristic is of decreasing nature and the magnitude of torsional vibration, characterised by a dynamic twist angle, ranges from  $\varphi_d = 0,65^\circ \div 0,25^\circ$ . This is due to the fact that, in case of trouble-free operation of the piston machine, the secondary harmonic components ( $i=1$  and  $2$ ) have a very low torsional excitation potential. Their potential increases if failure of the piston machine occurs (characteristics *b*, *c*). In the event of uneven excitation of the individual compressor cylinders, at the critical speed locations for  $i = 2$ , the magnitude of the torsional vibration increases almost 13-fold compared to the failure-free operation of the piston machine, which represents the dynamic twist angle  $\varphi_d = 1,15^\circ$  ( $\varphi_d = 0,7^\circ$  for  $i=1$ ), while in the case one cylinder is out of order, it reaches up to 60-fold value, which causes an increase in the dynamic twist angle to  $\varphi_d = 4,1^\circ$  ( $\varphi_d = 3^\circ$  for  $i=1$ ).

The momentary reduction of dynamic load by controlling the torsional vibration would be of great importance for each MSTV in such cases.

The presentation of how torsional vibration was controlled, as well as mechanical jitter of the system at hand by static optimisation based on the method of extremal regulation was performed under the following conditions:

- during stable operating mode of a given system, that is, at constant operating speed in the range of  $n = 1000 \div 2500 \text{ min}^{-1}$  characterised in Fig. 11 and Fig. 12 in positions (1) to (10).
- provided the piston machine fails when one cylinder stops working.

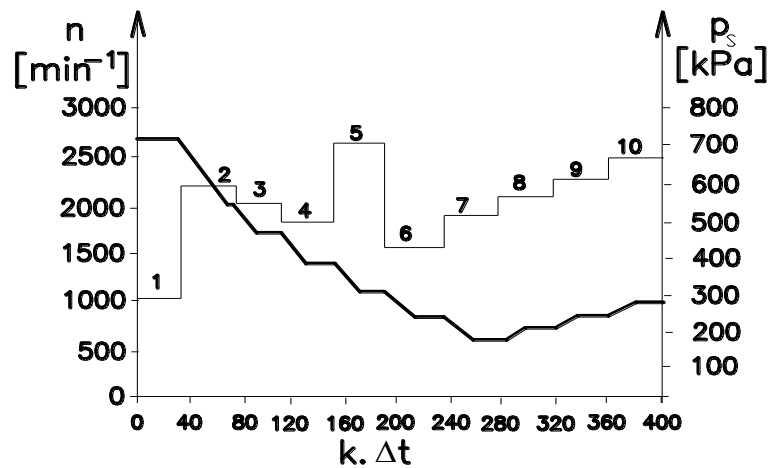

Fig. 11. The result of the static optimisation of the implemented system, characterised by the change in the value of the action variable  $p_s$  at the speed range  $n$ , dependent on the discrete time  $k. \Delta t$ .

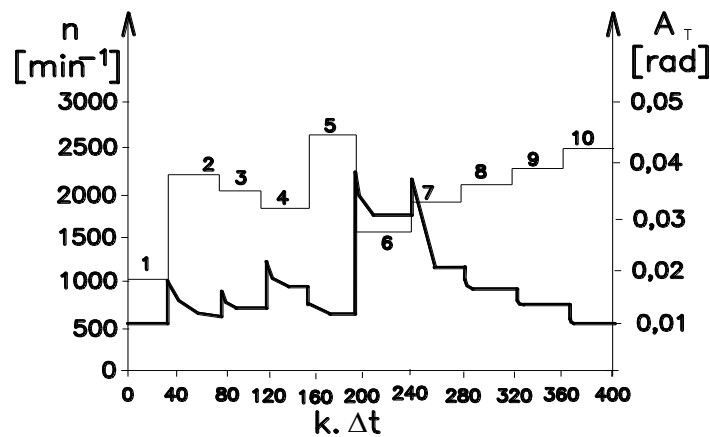

Fig. 12. The result of the static optimisation of the implemented system, characterised by a change in the value of the controlled variable  $A_T$ , at the operating speed range  $n$ , dependent on the discrete time  $k. \Delta t$ .

The results of the static optimisation are achieved by controlling the pressure of the gaseous medium  $p_s$  in the pneumatic tuner (Fig.11) and then regulating the torsional vibration magnitude of the  $A_T$  system (Fig.12), that is, by stabilising it, particularly, in ten random operating modes. Given that this is a simulation of extremal regulation, any change in the working mode, that is, the operating speed is in this case at hand done by a jump.

Let us assume the MSTV operates, for example, in the fifth operating mode, characterised by the speed  $n_5 = 2500 \text{ min}^{-1}$ . In this case, the pressure of the gaseous medium in

the pneumatic tuner stabilised at  $p_{S5} = 278 \text{ kPa}$  and in terms of torsional vibration, the system is stabilised when the value of  $A_{T5} = 0,01 \text{ rad}$  ( $0,57^\circ$ ). By changing the operating mode from  $n_5 = 2500 \text{ min}^{-1}$  to  $n_6 = 1400 \text{ min}^{-1}$ , the magnitude of torsional vibration increases from  $A_{T5} = 0,01 \text{ rad}$  to  $A_{T6} = 0,03 \text{ rad}$  ( $2^\circ$ ). Through monitoring the given system, the optoelectronic sensor sends an electrical signal to the extremal controller. Based on the results of the control algorithm (Fig. 9) of the extremal regulator, the pressure of the gaseous medium is reduced from  $p_{S5} = 278 \text{ kPa}$  to the stable value of  $p_{S6}^* = 219 \text{ kPa}$ . By varying the overpressure of the gaseous medium, the dynamic torsional stiffness of the *pneumatic tuner*  $k_d$ , is regulated, resulting in a change in the system's inherent frequency  $\Omega_0 = \sqrt{k_{ed}/I_{red}}$ . The amplitude value of the dynamic component of the pneumatic tuner twist angle according to (2) depends basically on the frequency ratio of the  $i$ -th harmonic component of the torque load and the intrinsic frequency of the system ( $i\omega/\Omega_0$ ). This means that the magnitude of the torsional vibration of the mechanical system  $A_T$ , characterised by the dynamic component of the twist angle, will depend on the change in the pressure of the gaseous medium in the compressor space of the tuner.

In this particular case, the reduction of the pressure of the gaseous medium ( $p_{S5}$  to  $p_{S6}^*$ ) as an action variable causes a reduction in the magnitude of the torsional vibration, that is to say, the controlled quantity from the  $A_{T6} = 0,035 \text{ rad}$  to the stable value of  $A_{T6}^* = 0,025 \text{ rad}$  ( $1,4^\circ$ ).

It can be inferred from the above that in the sixth operating mode, in terms of torsional vibration magnitude, the MSTV stabilised at the value of  $A_{T6}^* = 0,025 \text{ rad}$ .

Since the parameters of regulating the system's dynamic characteristics are not yet known (they are currently being established in experimental measurements), the values ( $n$ ,  $p_S$ ,  $A_T$ ) are shown in Fig. 11 and Fig. 12, respectively, depending on the discrete time  $k \cdot \Delta t$  for 400 simulation steps.

#### 4. CONCLUSION

Among other things, the results of this paper confirm that dangerous torsional vibration of any mechanical system can be reduced to an acceptable level by suitably adapting the dynamic properties of the pneumatic torsional tuners. This means that mechanical systems with torsional vibrations need to be pre-tuned or tuned in advance. In order to tune the mechanical systems with torsional vibrations, it is necessary to do a detailed dynamic calculation in terms of torsional vibration. If powerful turbocharged diesel engines are used in mechanical systems, the dynamic calculation is not sufficient only for balanced excitation of the individual engine cylinders. It must be borne in mind that during a system operation mode, unforeseen (accidental) fault effects may occur, most often characterised by a failure of the piston device itself. The excitation of individual cylinders of the diesel engine is practically uneven, and at the same time, a cylinder that stops working is a very frequent failure effect of the piston device. As a result of this, there is a clear increase in torsional vibration of the mechanical system and the entire device jitters. This causes increased dynamic stress on the individual parts of the mechanical system and, in particular, of the flexible shaft coupling, as being relatively the weakest part of the mechanism.

Reining in dangerous torsional vibration of mechanical systems operating with a wide range of revolutions is currently done by using very flexible couplings with appropriately chosen nonlinear characteristics. Only some types of flexible couplings are able to meet this requirement because not all types of couplings enable reaching sufficiently low torsional stiffness while maintaining sufficiently suitable strength properties. The torsional stiffness

and strength properties depend on the shape of the elastic element and the material from which the elastic element was made. At the same time, it should be noted that any linear or non-linear flexible coupling currently used has only one characteristic. This fact then translates into only one trend of its inherent speed frequencies in the Campbell diagram. To change the characteristics of the flexible coupling to fit its dynamic properties with the dynamics of the system means to use another element of the flexible coupling or to use another flexible shaft coupling. In any case, fatigue and ageing of elastic materials cannot be overlooked, which ultimately greatly affect the original dynamic properties of the coupling. Thus, the transience of dynamic properties of elastic couplings caused by ageing and fatigue of their elastic elements, as well as the frequent failure of some other members of the system, causes the pre-tuned mechanical system with torsional vibration to misalign. In such a case, its tuning member, that is, the flexible shaft coupling is in no position to eliminate or reduce increasingly dangerous torsional vibration.

In view of the above and with the aim of tuning the mechanical systems with torsional vibration to limit dangerous torsional vibration, we have proposed using the pneumatic torsional tuners developed by us. These pneumatic tuners do not have one, but a whole range of characteristics, as well as a range of the typical ones. The properties of these tuners are mainly influenced by the change in the pressure of the gaseous medium in its compression space.

Based on the results of the experimental verification, we noted that by changing the pressure of the gaseous medium in the compressor space of the pneumatic tuner, change in its dynamic torsional stiffness was achieved, which had a decisive influence on the system's inherent frequency. The essence of the principle of tuning mechanical systems with torsional vibration with pneumatic tuners lies in the adaptation of the intrinsic angular frequency of the mechanical system to the excitation angular frequency, so no resonance condition emerges during the system's operating mode and consequently, no dangerous torsional vibrations occur.

Based on the results of the analysis of balanced excitation, uneven excitation of individual engine cylinders and the failure of one cylinder, which stopped working, it can be stated that the introduced pneumatic tuner has met all the requirements for its application in mechanical systems with torsional vibration with constant operating speed and operating speed range. At the same time, it was also confirmed that it is possible to reduce the unfavourable consequences of unforeseen breakdown effects occurring in mechanical systems by optimising the mechanical systems with torsional vibration as proposed. The optimisation in question is a static optimisation of the mentioned system during operation in a stable condition, which we proposed to ensure that by using the method of extremal regulation through the step change in the action variable. The results of the simulation confirmed that the static optimisation of the mechanical systems by using the indicated method translates into reduction in dangerous torsional vibration in any mechanical system with torsional vibration.

Finally, it can be argued that the proposed manner of tuning (continuous system tuning) in operation can be applied wherever the need to prevent dangerous torsional vibrations of mechanical systems exists. The presented results confirm that these tuning methods can contribute to increasing the technical level and operational reliability of all mechanical systems with torsional vibration into which they are incorporated.

### Acknowledgements

This paper was written within the framework of the Grant project VEGA 1/0473/17 “Research and development of technology for homogeneous charge self-ignition using compression in order to increase engine efficiency and to reduce vehicle emissions.”

### References

1. Böhmer Jürgen. 1983. „Einsatz elastischer Vulkan-Kupplungen mit linearer und progressiver Drehfedercharakteristik”. [In German: „Use of elastic volcano couplings with linear and progressive torsion spring characteristics”]. *Motortechnische Zeitschrift* 44(5): 21-24.
2. Lunke Martin, Beftink G. Bernd. 1983. „Einsatz hochelastischen Kupplungen in energiesparenden Schiffsantriebsanlagen”. [In German: „Use of highly flexible couplings in energy-saving marine propulsion systems”]. *Schiff und Hafen* 4(35): 23-32.
3. Zoul Václav. 1982. „Některá hlediska vývoje pružných spojek pro soustrojí s naftovými motory”. [In Czech: „Some aspects of development of flexible couplings for diesel engines”]. *Strojírenství* 32(6/7): 21-28.
4. Lacko Pavol, Vladimír Lacko. 2000. „Continuously driven resonance”. *Strojárstvo* 42(3/4): 127-135.
5. Zoul V., P. Utěkal. 1978. „Výskum vlastností nelineárni pružné spojky”. [In Slovak: „Research of properties of nonlinear flexible coupler”]. *Strojírenství* 28(5): 25-34.
6. Ubartas M., V. Ostaševičius, S. Samper, V. Jūrėnas, R. Daukševičius. 2011. „Experimental investigation of vibrational drilling”. *Mechanika* 4: 368-373.
7. Kubík S. 1982. *Teorie automatického řízení II. (Optimální, adaptivní a učící se systémy)*. [In Czech: *Theory of Automatic Control II. (Optimal, Adaptive, and Learning Systems)*]. Praha: SNTL.
8. Rastrigin A.A. 1974. *Sistemy ekstremalnogo upravlenija*. [In Russian: *Extreme management systems*]. Moscow: FML.
9. Pešík L., Němeček P. 1997. *Identification of the dynamic system of a machine with an elastic base*. McNU 97, Chicago, USA.
10. Yubao S., W. Jihong, Y. Dianlong, W. Xisen. 2013. „Analysis and enhancement of torsional vibration stopbands in a periodic shaft system”. *Journal of Physics D: Applied Physics* No 46 145306: 7-13. ISSN 0022-3727.
11. James D. Van de Ven, J. Cusack. 2014. „Synthesis and baseline testing of a digital pulse-width-modulated clutch”. *Mechanism and Machine Theory* 78: 81-91. ISSN 0094-114X.
12. Mehlan A. 1996. „Hocheleustische Kupplungen”. [In German: „Highly elastic couplings”]. *Antriebstechnik* 35(11): 27-33.
13. Sága M., L. Jakubovičová. 2014. „Computational analysis of contact stress distribution in the case of mutual stewing of roller bearing rings”. *Novel Trends in Production Devices and Systems, Applied Mechanics and Materials* 474: 363-368.
14. Czech P. 2011. „Diagnosing of disturbances in the ignition system by vibroacoustic signals and radial basis function - preliminary research”. *Communications in Computer and Information Science* 239: 110-117. 11th International Conference on Transport Systems Telematics (TST 2011). Katowice-Ustron, Poland, October 19-22, 2011. *Modern Transport Telematics*. DOI: [https://doi.org/10.1007/978-3-642-24660-9\\_13](https://doi.org/10.1007/978-3-642-24660-9_13).

15. Ostaševičius V., I. Milašauskaitė, R. Daukševičius, V. Baltrušaitis, V. Grigaliūnas, I. Prosyčėvas. 2010. „Experimental characterization of material structure of piezoelectric PVDF polimer”. *Mechanika* 6: 78-82.
16. Leskova Andrea, Hubert Jurjewicz, Patrik Lenghart, Peter Bacik. 2018. “Current challenges of digital technologies”. *Komunikacie* 1a. ISSN: 1335-4205.

Received 21.02.2019; accepted in revised form 19.05.2019



Scientific Journal of Silesian University of Technology. Series Transport is licensed under a Creative Commons Attribution 4.0 International License