

Tadeusz OPASIAK¹, Damian GAŚKA², Grzegorz PERUŃ³, Bogusław ŁAZARZ⁴

INFLUENCE CONSTRUCTION OF THE ROLLER ON THE POWER OF THE DRIVE SYSTEM OF THE BELT CONVEYOR

Summary. The paper presents a study of new design of rollers. The study focused on the measurement of static and dynamic resistance of rotating rollers and the impact of new construction on the power consumption of the belt conveyor. Rollers have been modified through the use of class C4 bearing seals and labyrinth seal U4Exp 62/65 with a cover 2LU4 of runner construction. Measurements of static and dynamic resistance of rotating rollers were made on a universal rollers stand and power measurements were carried out on a belt conveyor power supply system Gwarek 1200 No. TW in mine KWK Mysłowice–Wesoła.

Keywords: belt conveyor, belt rollers, bearings, static resistance, dynamic resistance.

WPLYW KONSTRUKCJI KRĄŻNIKA NA MOC POBIERANĄ PRZEZ SYSTEM NAPĘDOWY PRZENOŚNIKA TAŚMOWEGO

Streszczenie. W artykule omówiono wpływ konstrukcji krążników na wielkość mocy pobieranej przez układ zasilania układu napędowego przenośnika taśmowego. Przedstawiono również wyniki pomiaru oporów statycznych i dynamicznych obracania się nowej i starej konstrukcji krążników zastosowanych w badanym przenośniku. Badane krążniki zostały zmodyfikowane przez zastosowanie uszczelnienia klasy C4 w łożyskach oraz uszczelnienia labiryntowego U4Exp 62/65 z pokrywą 2LU4 w konstrukcji krążnika. Pomiar statycznego i dynamicznego oporu obracania krążników wykonano na stanowisku do badań krążników, natomiast pomiary poboru mocy przenośnika – na instalacji zasilającej przenośnik taśmowy Gwarek 1200 nr TW w KWK Mysłowice-Wesoła.

Słowa kluczowe: przenośnik taśmowy, krążniki, łożyska, opór statyczny i dynamiczny.

¹ Faculty of Transport, The Silesian University of Technology, Department of Logistics and Mechanical Handling, Katowice, Poland, e-mail: tadeusz.opasiak@polsl.pl

² Faculty of Transport, The Silesian University of Technology, Department of Logistics and Mechanical Handling, Katowice, Poland, e-mail: damian.gaska@polsl.pl

³ Faculty of Transport, The Silesian University of Technology, Department of Automotive Vehicle Construction, Katowice, Poland, e-mail: grzegorz.perun@polsl.pl

⁴ Faculty of Transport, The Silesian University of Technology, Department of Automotive Vehicle Construction, Katowice, Poland, e-mail: boguslaw.lazarz@polsl.pl

1. INTRODUCTION

Rollers, on which the conveyor belt moves during its run are the large number of components of the belt conveyor. Their effective functioning depends on: the correct run of a conveyor belt and its durability and resistance to motion of a belt conveyor. Therefore, it is very important for proper mounting of the roller on conveyor support structure. Rollers has usually bearings with one row of balls to have the lowest rolling resistance. It is essential to proper sealing of the chamber to prevent leakage of the bearing lubricant and the ingress of water and other contaminants.

In order to assess the rotate resistance of the structure rollers movement and power consumption of the drive unit of the belt conveyor, an analysis was carried according to the following scheme:

Measurements of energy consumption a belt conveyor type Gwarek 1200 KWK Mysłowice-Wesoła with currently used rollers.

Then replacing the rollers in the belt conveyor type Gwarek 1200 KWK Mysłowice-Wesoła on new rollers of a new type of company SAG with bearing 6305 SKF ETN9/C4 type with a basket of glass fiber reinforced polyamide and labyrinth seal U4Exp 62/65 with a cover 2LU4 typu.

Measurements of energy consumption in the belt conveyor type Gwarek 1200 on three times measuring cycles with one times month between measurements.

Checking static and dynamic resistance of rotating rollers previously used in the belt conveyor type Gwarek 1200 and new rollers of new construction (fig. 1) from company SAG, both before installation and after two months of continuous operation.

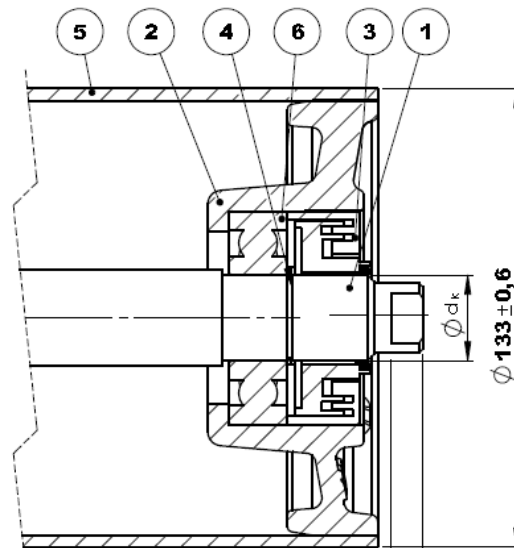

Fig. 1. New structure of roller by SAG Sp. z o. o. [8]: 1 – axis, 2 – cast iron hub, 3 – labyrinth seal, 4 – stopper ring SEG Z025, 5 – jacket $\phi 133$, 6 – bearing 6305 ETN9/C4 [7]

Rys. 1. Krążnik nowej konstrukcji firmy SAG Sp. z o.o. [8]: 1 – oś, 2 – piasta żeliwna, 3 – uszczelnienie labiryntowe, 4 – pierścień osadczy SEG Z025, 5 – płaszcz $\phi 133$, 6 – łożysko 6305 ETN9/C4 [7]

2. MEASUREMENTS OF STATIC RESISTANCE TO TURN ROLLERS

Measurements of the static resistance of rotating rollers performed on universal testing rollers a measure stand (Fig. 2) which to this task has been prepared. The axis (2) of testing the roller (1) was fixing in canines position and secured against rotation move. On the part of rotational fix two-armed a lever (3) was determined using three set screws (6). After this preparatory leveled by applying the two-armed lever one arm of the respective size of the weight (4). Next on the second lever arm length $L_s = 206$ [mm] further suspended mass (5). The measurement was to determine the size of the static torque at a roller which begins to rotate [1,2,3,4,5].

The amount of torque called the "moment of resistance of the static runner" was calculated with the following formula

$$M_S = m \cdot g \cdot L_S [Nm] \quad (1)$$

where: M_S - moment of resistance of the static [Nm], m - mass of the load lever [kg], $g=9.81$ [m/s²], $L_s = 0.207$ [m]:

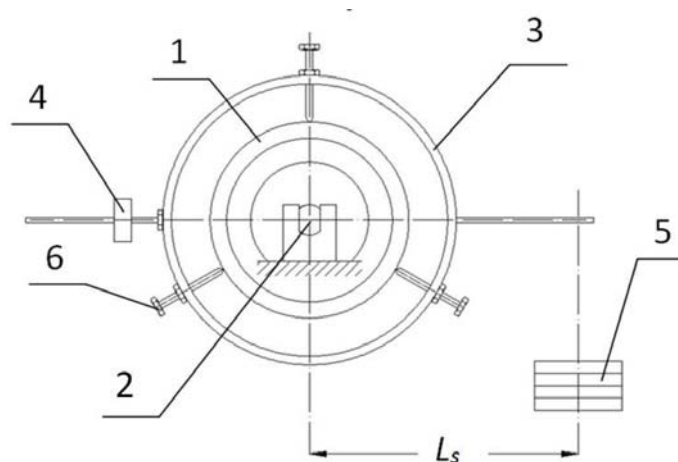

Fig. 2. The laboratory stand for the measurement of rollers static resistance: 1 – roller, 2 – roller axis, 3 – lever, 4 – levelling mass, 5 – load mass, 6 – binding screw

Rys. 2. Stanowisko do pomiaru statycznego oporu obracania krążników: 1 – badany krążnik, 2 – oś krążnika, 3 – dźwignia dwuramienna, 4 – masa poziomująca, 5 – masa obciążenia, 6 – śruba dociskowa

Table 1

The average values of friction to rotate

Lp.	Studied a roller	M_s
1	upper side of rollers $\phi 133 \times 465$	0,020 Nm
2	upper middle of roller $\phi 133 \times 465$	0,023 Nm
3	bottom toller $\phi 133 \times 670$	0,014 Nm

Comparing the results obtained with the book of standards [6] states that the roller after test reaching achieved very high operating parameters, which consequently affect positively on their durability.

3. DYNAMIC RESISTANCE ROTATION OF THE ROLLERS

Dynamic resistance measurements were performed on rotating rollers position where the roller axis was fixed. This method eliminates influence of roundness of shell on the measurement result, while no effect on the magnitude of the measured force. The amount of force results from the relative movement with respect to the axis of the roller shell. This movement is unchanged regardless of whether or mantle rotates the roller axis. The axis of the roller (6) is fixed on one side of a rotatable handle (4) via which rotation is transmitted from electric engine (2) by a belt transmission (3). On the other hand, is supported on the axis of quill (5). To the engine driving the measuring position, the inverter is connected with which to maintain a constant rotor speed (it is possible to control the speed of the engine). During the measurement speed was constant at 600 RPN. To shell of the roller clamp ring is attached to the arm based on the weight, so that the roller shell is immobilized. During the rotation axis relative movement of the axis of the shell and causes torque which is transmitted to the arm (9) of fixed length or weight. The resulting value is reduced to the outer radius of the shell of the equilibrium equation of moments (fig. 3) [1,2]:

$$P_w \cdot g \cdot L_k = W_k \cdot r_p \quad (2)$$

and after transformation:

$$W_k = \frac{P_w \cdot g \cdot L_k}{r_p} \quad (3)$$

where: P_w - recorded force [N], L_k - arm length [m], g - acceleration due to gravity [m/s^2], r_p - radius of the outer shell of roller [m], W_k - the dynamic resistance value of the roller [N].

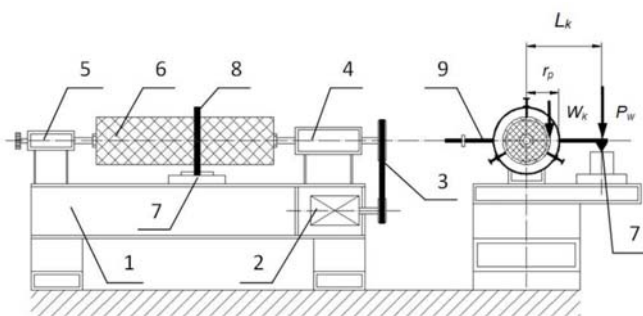

Fig. 3. The laboratory stand for the measurement of rollers dynamic resistance: 1 – load carrying structure, 2 – electrical engine, 3 – belt transmission, 4 – drive shaft support, 5 – clamp shaft support, 6 – roller, 7 – electronic balance, 8 – roller clamping ring, 9 – lever

Rys. 3. Stanowisko do pomiaru dynamicznego oporu obracania krążników: 1 – podstawa stanowiska, 2 – silnik elektryczny, 3 – przekładnia pasowa, 4 – podpora wałka napędowego, 5 – podpora wałka dociskowego, 6 – krążnik, 7 – waga pomiarowa, 8 – obejma krążnika, 9 – dźwignia dwuramienna

Measurements were performed for new construction of a rollers SAG company immediately after installation (assuming their 20 minute work on the laboratory stand) (fig. 3) and two-month work in coal mine. In addition, the measured dynamic resistance of standard rotating rollers previously used in a conveyor type Gwarek 1200 after about a year of continuous operation. For each of the three rollers carried out in attempts to measure the dynamic resistance of the rotation, and then the average value was calculated (tab. 2, tab. 3, tab. 4) [1,2].

Table 2

Dynamic resistance of the rollers used so far on mine (after work)

Measurement range	P _w [g]	W _k [N]	L _k [m]	r _p [m]
Average	89,64	2,73	0,207	0,0665
Deviation	12,90	0,39	0,207	0,0665
Max	106,7	3,21	0,207	0,0665
Min	64,1	1,92	0,207	0,0665

Table 3

Resistance dynamic new company rollers SAG Sp. z o

Measurement range	P _w [g]	W _k [N]	L _k [m]	r _p [m]
Average	65,6	2,00	0,207	0,0665
Deviation	12,79	0,39	0,207	0,0665
Max	89,0	2,72	0,207	0,0665
Min	47,0	1,43	0,207	0,0665

Table 4

Resistance dynamic new company rollers SAG Sp. z o after
2 months of work

Measurement range	P _w [g]	W _k [N]	L _k [m]	r _p [m]
Average	35,75	1,09	0,207	0,0665
Deviation	1,517	0,04	0,207	0,0665
Max	38	1,16	0,207	0,0665
Min	32	0,97	0,207	0,0665

4. MEASUREMENTS OF POWER CONSUMPTION TYPE GWAREK 1200

Measurements were made on the supply line conveyor Gwarek 1200 No. TW KWK Myslowice-Wesoła, which transports the excavated material to the mine pit shaft „Carol” on pit 665 m. The belt conveyor drive consists of two electric motors and 90 kW 1477RPN each. Network parameters are 1000 V, 50 Hz. Frictional engagement is realized by two drums drive $\phi 1000 \times 1400$ (rubber wheels) embedded in the hulls of the drive unit. The measurement was conducted on the transformer station SENSITIVITY-10 Tr1 IT3Sb 400/6/1 which supplies the test station conveyor belt. Measurements were made on the supply lines L1, L2, L3 [1,2].

Power measurement (tab. 5) was carried out indirectly by measuring the current at the time of starting and running movement fixed belt conveyor with simultaneous measurement of power factor \cos . Conveyor belt at the time of measurement was powered on broken coal material with output of 750 ton per hour. Active power consumption was determined from the relationship:

$$P = \sqrt{3} \cdot U_p \cdot I_f \cdot \cos \varphi [W] \quad (4)$$

where: P – power, U_p – voltage wire, I_f – phase current, $\cos \varphi$ – power factor.

Table 5

The results of power measurements

Lp.	The results of power measurements	Current [A]	Power factor $\cos \varphi$	Power P [kW]
1.	Operation of the conveyor with the standard roller on start-up	93,2	0,86	139,3
2.	Operation of the conveyor with standard rollers in steady motion	68,13	0,86	102,0
3.	Operation of the conveyor of the roller from company SAG at start-up (measurement three days after installation)	86,84	0,86	129,4
4.	Operation of the conveyor of rollers company SAG in steady motion (measured 3 days after installation)	65,16	0,86	97,5
5.	Operation of the conveyor of rollers company SAG in steady motion (measured after 30 days of operation)	64,42	0,86	96,0
6.	Operation of the conveyor of roller company SAG in steady motion (measured after 60 days of operation)	63,65	0,86	94,8

5. CONCLUSIONS

When using rollers new construction company SAG power consumption, both at start-up and operating a fixed, decreased by 7.1% in the belt conveyor Gwarek type 1200 KWK Myslowice-Wesoła. The use of bearings SKF 6305 ETN9/C4 with a basket of glass fiber reinforced polyamide results in the presence of a very small static resistance turn the roller (0,014 ÷ 0,020 Nm, which is 7 ÷ 10% of the limit). Use Class C4 bearing seals and seal runner U4Exp 62/65 with a cover design 2LU4 runner, resulting in exceptionally low drag dynamic movement (of 1.43 ÷ 2.72 N - 31.78 ÷ 60.44% of the maximum normalized) also after the two months of operation (value 0.97 ÷ 1.16 N - 21.55 ÷ 25.78% of the maximum normalized) in difficult operating conditions (dust and humidity) in coal mine Myslowice-Wesoła.

Bibliography

- Opasiak T., Gąska D., Łazarz B.: Analiza oporów ruchu przenośnika taśmowego i krążników w KWK Myslowice-Wesoła. Konferencja Międzynarodowa PKM, Szczyrk 2013 (materiały konferencyjne).
- Opasiak T.: Badanie nowej konstrukcji krążników firmy SAG. XXI Międzynarodowa Konferencja Naukowo-Techniczna Temag 2013, Trwałość Elementów i Węzłów Konstrukcyjnych Maszyn Górniczych, Ustroń 2013.
- Bukowski J., Gładysiewicz L.: Metoda badań oporów obracania krążników pod obciążeniem. Transport Przemysłowy i Maszyny Robocze, 1/2010.
- Gładysiewicz L., Król R.: Badania wpływu warunków eksploatacyjnych na opory obracania krążników. Transport Przemysłowy, 2/2003.
- Król R.: Badanie statycznych i dynamicznych oporów obracania krążników stosowanych w przenośnikach taśmowych. Instytut Górnictwa Politechniki Wrocławskiej, Wrocław 2009.
- PN-M-46606:2010: Belt conveyor – Roller.
- SKF Bearing – catalog 2013.
- Katalog firmy SAG Sp. z o.o.